

LAMINAIR™

Compact laminar airflow system
designed for Operating Theatres



www.rainbowfilters.com.au



History

Rainbow Filters was established in 1956, is still a current member of Australian Industry Group and have maintained a quality assurance certification since 1994, with more than 50 years of experience it can offer a complete range of air filtration products, solutions and services to meet all hospital and pharmaceutical markets requirements.

Surgical-site infection has always been the leading complication of surgery: normal skin flora of patients or hospital operators causes more than half all infections following clean surgery. To fight them, first clean air unit was introduced in 1966 in Writtington Hospital operating theatres, and since 1968 it has become a preferred system to be used where an ultra clean environment is paramount.

After so many years hospitals have the same need of clean air and continuous improvement has been driven by the desire to reduce the risk of infection overtaking some limits of traditional units:

- Poor design: filters placement doesn't minimize turbulences in airflow.
- Improper filtration: the use of ultra-clean air significantly reduces infections in surgery.
- Conventional systems are not designed to guarantee the min. 20 ACH recommended.
- Insufficient lights: often distant from the centre creating blind spots.

Laminair

Laminair™ series 2 system, with return air and integrated lights, guarantee to achieve all of these features.

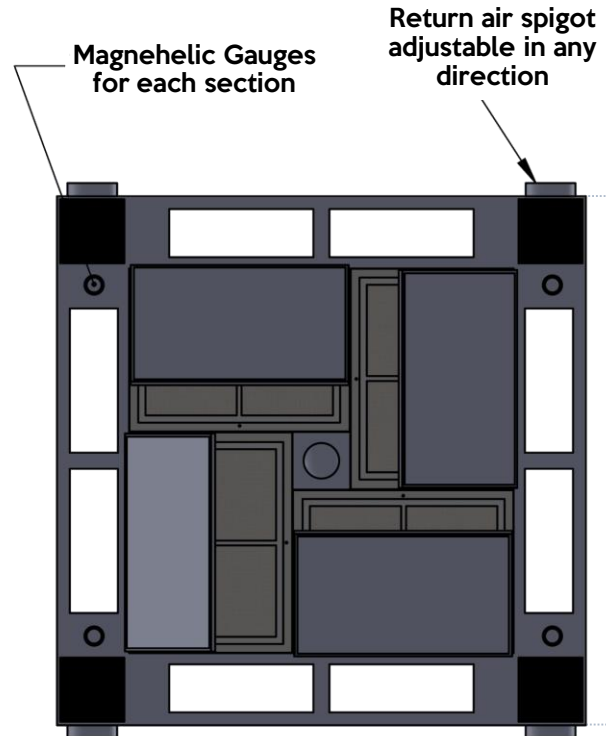

Laminair™ series 2 system

The functional design has been studied to reach the best airflow performance minimizing shadow spots and turbulences. **Laminair™** stand alone loop supply-exhaust is balanced to guarantee 20 ACH in areas until 200m³ (common OR are 50 m³).



Stainless steel screen

Each screen is provided with a **stainless micro mesh** which optimizes the performance of the unit, protecting the HEPA's and creating a uniform laminar airflow as never seen before in a UCV unit.

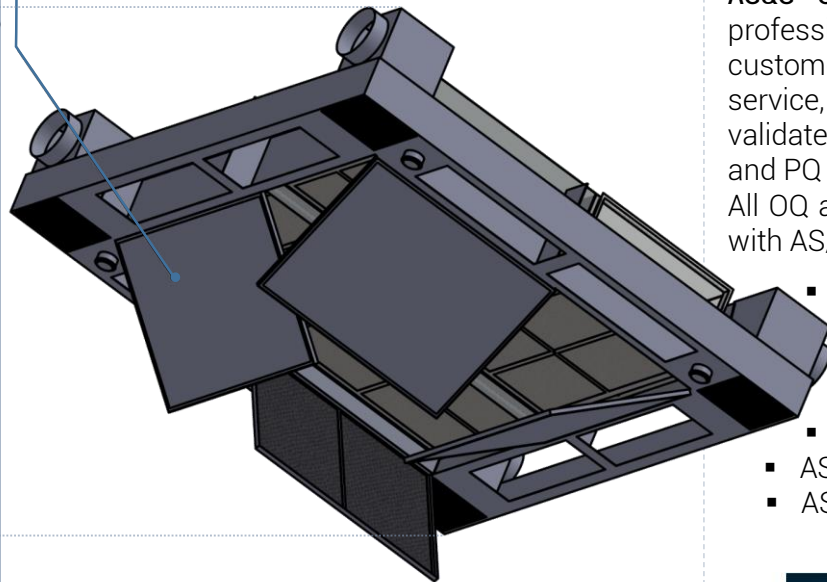

Laminair™ is in-house designed, it can be increased and customized depending on all customer needs. There's no limit to the variety of HEPA or ULPA filters that can be equipped in the unit, installed in frames with **mechanical sealant**

systems, avoiding the use of any gel (i.e. Blue gel) that makes extremely difficult maintenance operations and annual validations, resulting also in unavoidably gel leaks in the theatres over time.

IOPQ and NATA Validation

AG&G Services is proud of its reputation for professional service and commitment to customer satisfaction. To guarantee the best service, every system installed can be fully validated by our validation specialists with IQ, OQ and PQ protocols, both writing and execution. All OQ and PQ tests are performed in compliance with AS/NZS ISO 14644 standards, tests include:

- AS 1807.3 - Determination of **air velocity**.
- AS 1807.6 – **HEPA filter integrity**.
- AS/ISO 14644.1 - **Particle counting**.
- AS 1807.10 - **Air pressures**.
- AS 1807.13 - **Humidity & temperature**.
- AS 1807.15 - Determination of **illuminance**.
- AS 1807.16 - Determination of **sound level**.



INDEPENDENT CLEANROOM
TESTING SPECIALISTS



Innovative design

Laminair™ system is designed in compliance with ACHS and HTM guidelines, optimizing filtration surface minimizing the space between each filter, and uniformity reaching operating tables thanks to special stainless steel screens:

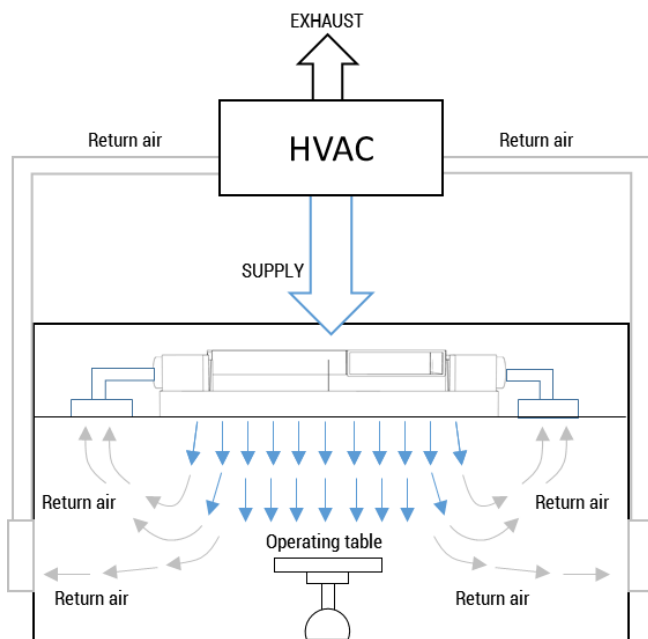

Laminair™ airflow patterns

The system constantly introduces filtered air in the theatre, diluting and purging old air pushing contamination far from critical areas, that always remain in a laminar airflow condition. Through this cycle temperature and relative

humidity are controlled and balanced giving the operators the maximum comfort, in compliance with AS 1807.13.

Components and Materials

System can be made with high quality materials such as: zinc seal steel, stainless steel AISI 304 / 316 or other custom materials, with epoxy paint, chromed, satin or scotch-brite finish, according to any customer need.

Integrated lights guarantee a perfect visibility on operating tables, in compliance with AS 1807.15 (> 800 Lux), low noise fans allow good performance in respect of AS 1807.16 (< 64 dB). **4 integrated magnehelic pressure gauges** permit a constant monitoring of filters condition through measuring their pressure drops.

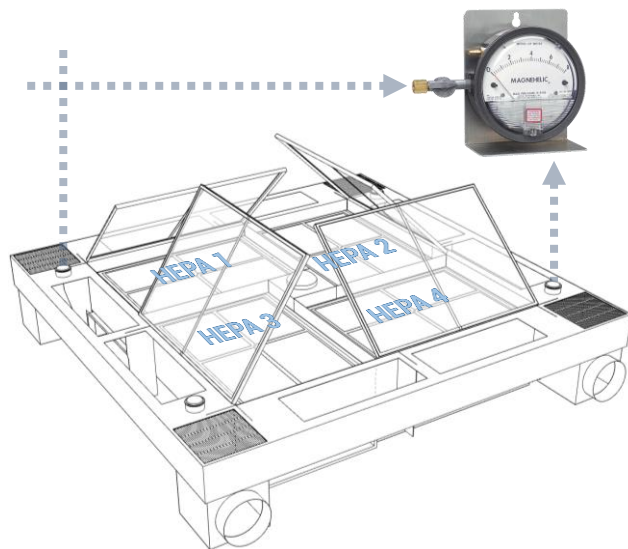

HEPA / ULPA Filter positioning

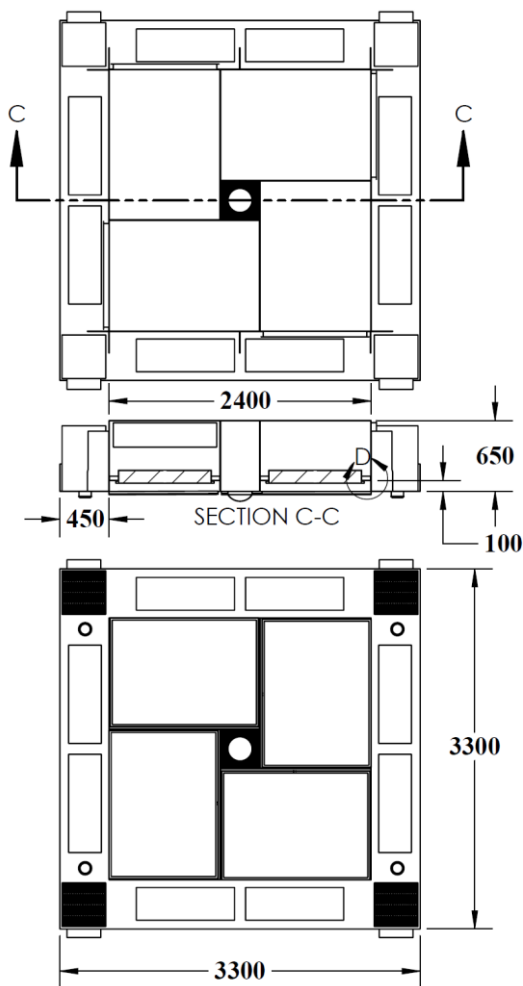

ISO Classification

The area surrounded by **Laminair™** laminar airflow can reach ISO 5 or greater class performance, fully compliant with *DHS Theatre Guidelines* requirements of ISO 6 class for UCV operating theatres.

UCV op. room particles concentration

— Laminair system performance

— DHS guidelines limit

	0.5 µm	1.0 µm	5.0 µm
ISO 1			
ISO 2	4		
ISO 3	35	8	
ISO 4	352	83	
ISO 5	3520	832	29
ISO 6	35200	8320	293
ISO 7	352000	83200	2930
ISO 8	3520000	832000	29300

ISO 14644.1 (2015) – Clean room and associated controlled environment

Total area [mm] HEPA area [mm] Airflow [L/s] Optional

Laminair™ Series 1

2800x2800

2400x2400

2500

/

Laminair™ Series 2

3300x3300

2400x2400

2500

Perimeter lights

FOR FURTHER INFORMATION



Office: 1300 365 659 – Fax: 1300 365 243



sales@rainbowfilters.com.au – www.rainbowfilters.com.au

